



HISTORY

Hans J. Wegner designed the CH33 for Carl Hansen & Son in 1957.

It was produced for 10 consecutive years before being taken out of production.

Carl Hansen & Son re-introduced the CH33 in 2012.

DESCRIPTION

The CH33 expresses many typical aspects of Hans J. Wegner's best design.

It is a very light, graceful chair that functions as a dining chair or as a sculptural addition to almost any room.

Every part of the chair employs rounded, organic forms.

The tapered legs and cross pieces are thickest where they need to support load-bearing joints, and gracefully become more slender as the design allows.

The slightly splayed legs make for a very robust construction and visually signal the light chair's structural stability.

The joints connecting the back legs to the backrest are visible classic examples of Hans J. Wegner's penchant for honest design that highlights good craftsmanship.

Seat and backrest is made from pressure-formed hardwood laminate.

It comes in all-wood versions, or with upholstered seat and back in the customer's choice of fabric or leather.

ENVIRONMENTAL INFORMATION

Carl Hansen & Søn and sustainability

People's fascination of the combination of good design and wood, as well as other natural materials, is something that transcends time and fashion. At Carl Hansen & Søn, we believe that this fascination helps to explain the great interest in our furniture, and we take very seriously concerns about the sustainability of the natural resources upon which we depend for our products. That is why we strive every day to improve our production methods, logistics and sales efforts in respect of scarce natural resources.

We buy wood only from sustainably managed forests. Oak, beech and ash come primarily from Danish forests which are managed according to the principles described in Denmark's National Forest Programme; some of these wood types are also sourced from other similarly managed European forests, or, in the case of walnut and cherry, North American forests.

We use every possible bit of these fine hardwoods in our furniture production. Inevitably, however, there are some scraps, which are then used to produce other products or recycled in district heating plants.

Tel: +1 212 242 6736

Fax: +1 (416) 572-4073

northamerica@carlhansen.com

THE DESIGNER

Hans J. Wegner was born in 1914 in Tønder, the son of a shoemaker. At the age of 17 he was apprenticed to a carpenter (H. F. Stahlberg) and it was at this time that he developed his first design. At the age of 20 he moved to Copenhagen to study at the institution now known as The Royal Danish Academy of Fine Arts, School of Design but which back then went under the more modest title of "The Artisan College."

He studied there from 1936-1938, before taking further studies as an architect. In 1940 Wegner initiated a joint project with Arne Jacobsen and Erik Møller in Aarhus, which involved fitting out Aarhus' town hall. It was also in 1940 that Wegner began to work with Master Carpenter Johannes Hansen, a man who played a significant role in bringing modern design to the Danish public. The then Copenhagen Industrial Art Museum (now Design Museum Denmark) purchased their first Wegner chair in 1942. Hans J. Wegner opened his own design studio in 1943, and in 1944 he designed his first "China Chair" in a series inspired by the Chinese Emperor's thrones.

One of the chairs in this series is what is probably Wegner's most famous work "The Wishbone Chair," which he designed in 1949, and which Carl Hansen & Søn have manufactured since 1950. Hans J. Wegner is regarded as one of the world's outstanding furniture designers. He was one of the motive forces behind the Danish Modern movement which did much to change people's view of furniture in the 1950s and 60s. His design retain relevance for us today and his sense for details is a source of constant wonder.

Wegner has received a number of prizes and recognitions. Amongst other things, he is an honorary member of The Royal Danish Academy of Fine Arts and has received an honorary doctorate from the Royal College of Art in London. He was also the first ever recipient of the Lunning Prize and received the 8th International Design Award in Osaka, Japan. His works are exhibited at major international museums including The Museum of Modern Art (MoMA) in New York and Die Neue Sammlung in Munich.

Hans J. Wegner died in Denmark in January 2007

Hans J. Wegner's contributions to Danish design:

- A master carpenter first and a designer second: Perfectly finished joints and exquisite forms.
- A deep respect for the wood and its character and an everlasting curiosity about good materials.
- He gave minimalism an organic and natural softness.
- He is considered as "the master chair-maker" and designed more than 500 chairs during the course of his life.

CONTACT INFORMATION

Europe

Carl Hansen & Søn Møbelfabrik A/S
Holmevænget 8
5560 Aarup
Denmark

Tel: +45 66 12 14 04
Fax: +45 65 91 60 04
info@carlhansen.com

Carl Hansen & Søn flagship store
Bredgade 21
1260 Copenhagen K

Opening hours:
Monday-Friday: 11am -6pm
Saturday: 11am - 4pm
Phone: +45 64 47 23 60

Rud. Rasmussen
Nørrebrogade 45
2200 Copenhagen N

Sales office London
+44 (0)75 35 888 285

Asia/Pacific

Carl Hansen & Søn Japan K.K.
10F 4-4-7 Kojimachi Chiyoda-ku,
102-0083 Tokyo
Japan

Tel: +81 03 3265 4626
Fax: +81 03 3265 4627
info@carlhansen.jp

America

Carl Hansen & Søn Inc.
462 Wellington St., West
Suite 502
Toronto, ON M5V 1E3
Canada

Carl Hansen & Søn Corp
304 Hudson Street
3rd Floor
New York, NY 10013
USA

VARIANTS CHOICES AND DIMENSIONS

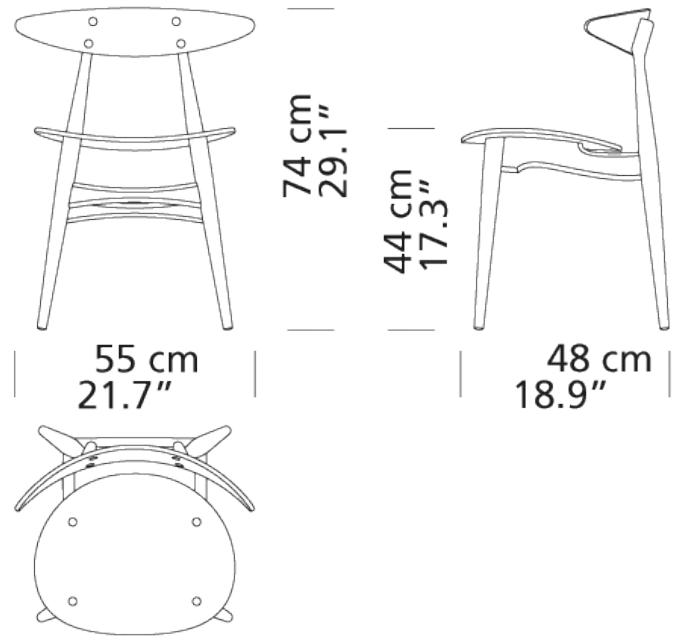

MATERIAL MATRIX

	Soap	Lacquer/Oil	CHS colors	White oil
Beech	●	●	●	
Oak	●	●	●	●
Smoked oak		●		
Oak/Walnut		●		
Smoked oak/Walnut		●		

TESTS AND CERTIFICATIONS

All tests and certificates are available on request.